



PRECISION POTENTIOMETER TUTORIAL

Before You Start"

"Selecting a potentiometer to meet your application seems fairly straightforward at first. You know the resistance or voltage profile you want to meet and the rest is up to the catalog... Then you start to think about your system needs: environment, tolerance buildups, rate and bandwidth. Do you need to trim for slope?"

Sensor Systems LLC's engineering and technical sales team are prepared to help you through the selection process, assuring the most cost effective potentiometer for your requirement. We have an extensive library of standard products to meet your needs, and stand ready to design for any custom requirements you might specify.

If you are not intimately familiar with specifying these components we invite you to read through the following short tutorial before you tackle the data pages.

MECHANICAL DESIGN ACTIVITY

Although the mechanical variations available in our standard configurations are numerous, **Sensor Systems LLC** supplies custom designs to fill all needs of the system designer. Special mounts, shaft configurations and non-standard sizes are all available. Your special designs can generally be accommodated without sacrifice of the standard characteristics of the **Sensor Systems LLC** potentiometer.

ELEMENT DESIGN

Varied and unique elements can be supplied to mount in systems or on existing components. **Sensor Systems LLC** will supply preferred mounting arrangements, methods of setting contacts, and operational procedures, so that the element will easily be accommodated in your production flow.

Linear as well as Functional potentiometric elements are available. Consult **Sensor Systems LLC** Applications Engineering Staff with your specific requirements.

DIRECTION OF ACTUATION

Rotary Potentiometers

Sensor Systems LLC potentiometers are truly bi-directional with insignificant errors resulting from CCW to CW shaft actuation.

Unless otherwise specified, all shaft directions in rotary potentiometers are considered to be counter clockwise (CCW), when the unit is viewed from the rear end; i.e. clockwise, when viewed from the mounting face. Voltage is

increasing from terminal 3, designated (-) to terminal 1, designated (+).

Rectilinear Potentiometers

Unless otherwise specified, the "Full-In" position is the minimum voltage potential and the "Full-Out" position the maximum voltage potential.

LIFE

The life of **Sensor Systems LLC** conductive plastic potentiometers in most applications is very long. This is due to the thin, smooth, continuous conductive film and its application to a substrate having a shape compatible to the form and travel of the precious metal wipers used throughout. The wiper attack angle is matched to the surface to give minimum wear and friction. Since the conductive film has a very low contact resistance component, wiper pressures in excess of 8 gms are not required, further improving life.

In most applications **Sensor Systems LLC** conductive plastic potentiometers will have a useful life of many millions of cycles, from a minimum of 5×10^6 to 100×10^6 full scale cycles in rotary configurations, and from 1×10^6 to 60×10^6 inches in rectilinear configurations.

Common life degradation tolerances are 1.5x initial specifications. **Sensor Systems LLC** potentiometers meet and often surpass these requirements. **Sensor Systems LLC** conductive plastic potentiometers meet and exceed all life requirements of MIL-R-39023.

Sensor Systems LLC wirewound potentiometers meet and exceed all life requirements of MIL-R-12934.

-- An Electromotive Solutions Company --

2800 ANVIL STREET NORTH • ST. PETERSBURG, FL 33710 USA • PHONE: (727) 347-2181 • Fax: (727) 347-7520

ACTUATION SPEED

As a general rule, the lower the actuation speed the longer the life. **Sensor Systems LLC** potentiometers are not particularly speed sensitive unless such speeds are high enough to produce wiper bounce, or other similar effects.

The preferred speed of actuation on rotary potentiometers is 100 R.P.M. or less with capabilities to 500 R.P.M. The preferred speed on linear motion potentiometers is 50"/sec. or less with capabilities to 100"/sec.

RESOLUTION

Resolution is defined as the smallest increment of shaft movement which will produce a corresponding change of output, or the minimum detectable voltage change with shaft movement.

The resolution of **Sensor Systems LLC** conductive film potentiometers is virtually infinite. Mechanical factors such as backlash, stiction, etc., have a much greater effect on discernible resolution than the film surface itself. As little as 5×100^{-6} " wiper motion will produce an output voltage change.

In a feedback servo system virtually infinite resolution permits high amplifier gains and improvement in frequency response. High performance servos are made possible without hunting.

In non-linear potentiometers, resolution is constant regardless of output voltage slope variations.

Wirewound units display a "staircase" output. The amplitude of each step is a function of the winding.

RESISTANCE

In an electrically discontinuous element, resistance, or terminal resistance, is the resistance of the potentiometer, measured in ohms, between the excitation terminals. In an electrically continuous element with excitation terminals 180° apart, (i.e. Sine-Cosine function) the resistance is equal to 1/4 of the entire ring resistance. This type of resistance notation is often referred to as "Resistance per Quadrant".

In **Sensor Systems LLC** potentiometers, the standard resistance tolerance is $\pm 10\%$ for conductive plastic units, and $\pm 5\%$ for wirewound units unless otherwise specified.

TAPS, DEFINED:

A tap is an electrical connection made to the resistance element at any point between the end terminals.

TAP TYPES & APPLICATION:

Two types of taps are available, as follows:

Zero-Width Tap:

A zero-width tap is one which does not effectively distort the output in the immediate area of the tap. From an output standpoint it is not discernible, and hence of zero-width. The zero-width tap is used to establish voltage reference points. Resistance between the terminal and the tap is approximately 4% of the terminal resistance.

Zero Resistance or Semi-Power Taps:

A zero resistance tap is one with a minimum resistance value, but one with a finite or discernible width. The net effect on the output of such a tap is a "dead band" or "flat", wherein the voltage across that band or "flat" is virtually constant, and does not change in accordance with the slope characteristics.

These taps are used for points of excitation, current drain, shunting, etc. See Fig. 2B below. The resistance between the tap and the terminal is virtually zero, i.e. 2-5 ohms. See table in "Optional Electrical Characteristics" section for actual value of width and current.

END POINTS:

End points, of themselves, are of no functional use to the user except as references to locate taps, etc. End points constitute the end of the function travel and the beginning of the overtravel.

Top Silver End Terminations: (CP Only)

A type of tap used for excitation, wherein the connection is placed on the conductive film. This is the most common connection which is used, and has an end resistance below 0.5Ω .

For certain applications requiring a smooth transition from end to function, this tap may not be suitable. See Fig. 1A.

Undersilver End Terminations: (CP Only)

Also used for excitation but one where the connection is placed beneath all or part of the conductive film. This type of end yields a smooth transition, but has a resistance between the wiper and the terminal of approximately 0.5% of the terminal resistance. See Fig. 1B.



An Electromotive Solutions Company
ISO 9001:2000 & AS9100:2004 Certified
2800 ANVIL STREET NORTH ST. PETERSBURG, FL 33710 USA
PHONE: (727) 347-2181 Fax: (727) 347-7520 Email: sales@vsensors.com

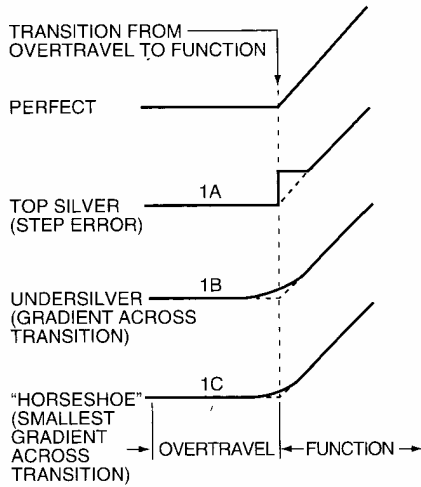

FIGURE 1

Horseshoe End Terminations: (CP Only)

A combination of 1A and 1B above, except the oversilver portion is absent from the wiper path. This sharpens the transition without producing the characteristics of the end resistance. See Fig. 1C.

INTEGRAL WING & SHUNT RESISTORS

The conductive film used in **Sensor Systems LLC** potentiometers can be deposited or otherwise fashioned so as to incorporate, integral to the element, both wing and shunt type resistors. Those areas of the film not traversed by the wiper are used for these functions. This capability is used extensively in producing non-linear functions.

Wing Resistor:

This resistive film is applied in a continuous layer and those portions to be used as wing resistor are physically isolated and connected between the electrical ends of the potentiometer and the excitation terminals. This isolated section acts as a fixed resistor and can be adjusted to obtain the exact value desired. There is, of course, no characteristics mismatch, thereby enhancing the function stability.

Wing resistors serve to drop the applied voltage across the potentiometer. Voltage variation over a portion of the applied voltage is thereby easily attained. See Fig. 2A.

Shunt Resistors:

Shunt resistors are formed in the same manner as wing resistors and are connected through taps (see applicable section) at specific points. Shunts serve to form parallel circuits in specific areas of the function. Shunts both with and without wings serve to generate complex and unique output curves. See Fig. 2B.

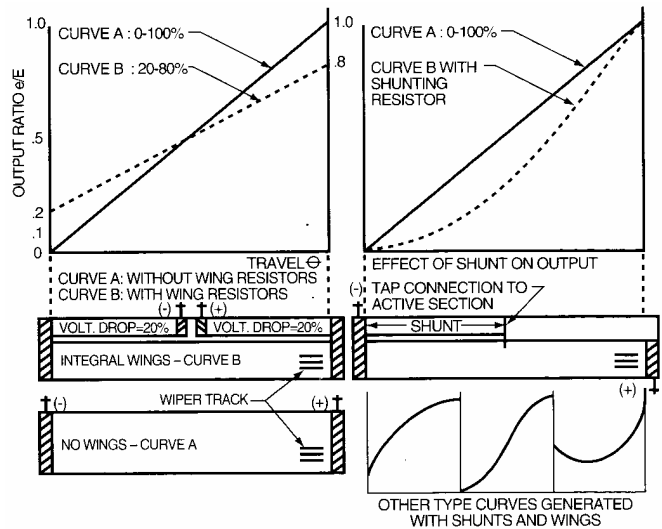

FIGURE 2A

FIGURE 2B

ACCURACY, LINEARITY AND CONFORMITY

Types of Data Supplied

Sensor Systems LLC potentiometers are supplied with data, upon request. In one of the following formats:

Check-off Data: Inspector stamped evidence of inspection.

Point by Point Data: Output data every 10° unless otherwise required.

Continuous Recording: Strip chart continuous error recording for Linearity and Output Smoothness.

Special Data: Special data and acceptance test procedures can be generated as required.

Linearity

"Linearity" and "Accuracy" defined: "Linearity" or "Accuracy" is the degree of proportionality of the output voltage with respect to the position of the shaft. It is expressed as a maximum deviation (in percent or applied voltage) from the desired output. Accuracy capability is dependent on size, length of function angle and length of stroke. The longer the active film the better accuracy potential.

A "linear" potentiometer is one where the output voltage is directly proportional to the angular or linear position of the shaft.



SENSOR SYSTEMS, L. L. C.
WWW.VSENSORS.COM

An Electromotive Solutions Company
ISO 9001:2000 & AS9100:2004 Certified
 2800 ANVIL STREET NORTH ST. PETERSBURG, FL 33710 USA
 PHONE: (727) 347-2181 Fax: (727) 347-7520 Email: sales@vsensors.com

There are several ways in which linearity can be specified. They are:

Independent Linearity:

Independent linearity is the maximum deviation of the actual voltage output from a "best" straight line reference whose slope and position minimize the maximum deviations. It is measured over the nominal electrical travel or function angle. The "best" straight line is that which can be obtained by the least-squares method of fitting to the data, or other similar means.

In practice, trimmer resistors are normally supplied in the user's system, one for each excitation terminal. The value of these resistors determine the slope and, hence, the position of the straight line reference. Such resistors are often referred to as pads, padders, or padding resistors.

STANDARD DATA FORM:

*Loaded-Continuous recording, or point-x-point, as applicable.

Unloaded-Continuous recording, or checkoff, as applicable.

*See applicable section on loading effects on page 7.

HOW TO SPECIFY:

Independent Linearity $\pm x.xx\%$

Function angle $xxx^\circ \pm x^\circ$, or $x.xx^\circ$.

Note: If the term "Linearity" only is used, it will be interpreted as **Independent Linearity** unless data or other descriptions indicate otherwise.

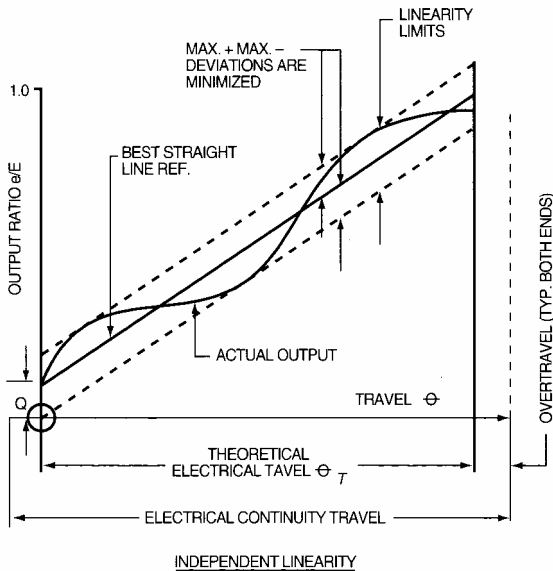

FIGURE 3

Mathematically: $e/E = P(\Theta / \Theta_T) + Q \pm C$

Where: P=unspecified slope

Q=unspecified slope intercept at $\Theta^\circ = 0$

C=Linearity tolerance

P & Θ chosen to minimize C: See diagram Fig. 3.

Zero-based Linearity

Zero-based linearity is the same as independent linearity except the best straight line reference is drawn through the zero-voltage output at the start of the function angle. Therefore, the origin of the straight line reference is fixed.

Only one padding resistor, attached to the maximum output terminal is used to adjust the slope of the line reference.

STANDARD DATA FORM:

Loaded-Continuous recording, or point-x- point data, as applicable.

Unloaded-Continuous recording, or check-off, as applicable.

HOW TO SPECIFY:

Zero-based linearity $\pm x.xx\%$

Function angle $xxx^\circ \pm x^\circ$, or $x.xx^\circ$.

Mathematically: $e/E = P(\Theta / \Theta_T) + B \pm C$

Where: P=Unspecified slope.

B=Specified slope intercept at $\Theta^\circ = 0$

See Fig. 4

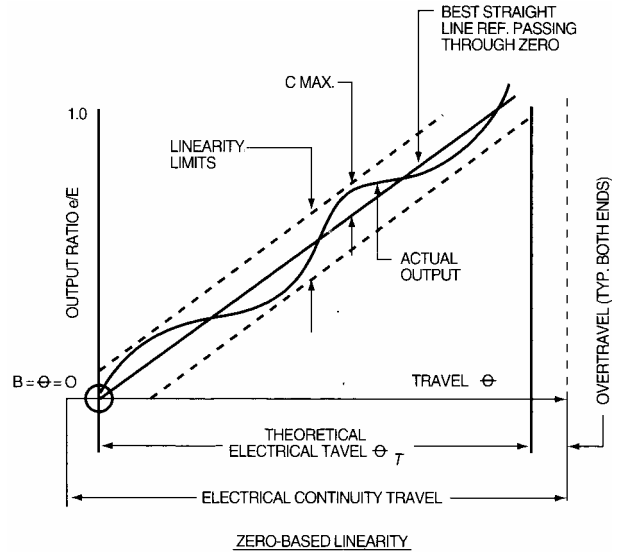

FIGURE 4.



An Electromotive Solutions Company
ISO 9001:2000 & AS9100:2004 Certified
 2800 ANVIL STREET NORTH ST. PETERSBURG, FL 33710 USA
 PHONE: (727) 347-2181 Fax: (727) 347-7520 Email: sales@vsensors.com

Terminal Linearity

Terminal linearity is the same as independent linearity except the straight reference line is fixed on both ends, and is drawn through the zero-voltage output at the start of the function angle, and through the maximum output at the end of the function angle. No padding resistors are used. The slope of the straight line is fixed and as such constitutes the theoretical output function.

See Fig. 5

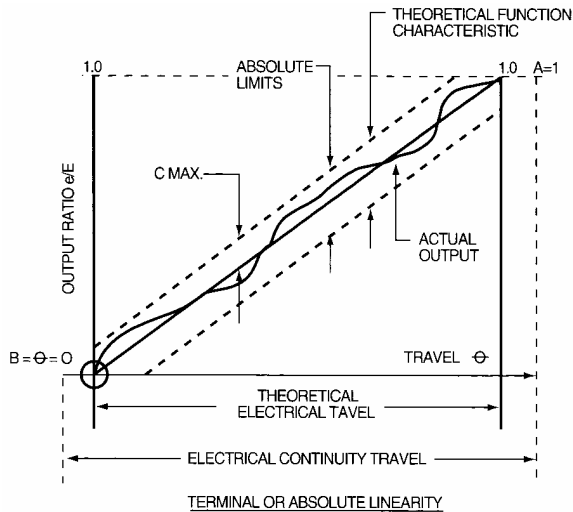

FIGURE 5

STANDARD DATA FORM: Point-x-point data.

HOW TO SPECIFY:

(1) Terminal linearity $\pm x.xx\%$ over a function angle of $xxx^\circ \pm x^\circ$.

(2) Terminal linearity $\pm x.xx\%$.

Excitation voltage, slope in volts/ $^\circ$ or volts/inch.

Mathematically: $e/E = A(\Theta / \Theta_T) + B \pm C$

Where: A=Specified slope

B=Given intercept at $\Theta^\circ = 0$

C=Linearity tolerance

Absolute Linearity

The term "Absolute Linearity" is merely an extension of terminal linearity in that it is the maximum output deviation from a straight line reference which is specified and fixed, and constitutes the theoretical output.

Absolute linearity is terminal linearity with no function angle tolerance. It is measured over all or part of the specified theoretical function travel and is expressed as a percentage of the total applied voltage.

The straight line reference may be fully defined by specifying the low and high end theoretical output ratios, and the theoretical function travel. Unless otherwise stated, end points will be interpreted as 0% and 100%. See Fig. 5.

STANDARD DATA FORM: Point-x-point data or strip recording.

HOW TO SPECIFY: Absolute Linearity $\pm x.xx\%$

Low end ratio $x.x\%$

High end ratio $x.x\%$

Function Travel xxx° or $x.xx"$ Ref.

Mathematically: $e/E = A(\Theta / \Theta_T) + B \pm C$

Where: A=Specified slope

B=Given intercept at $\Theta^\circ = 0$

C=Linearity tolerance

CONFORMITY

"Conformity" Defined: Conformity is the maximum deviation from a prescribed non-proportional output whose non-proportionality is a function of travel. Whereas linear potentiometers, by definition, have outputs proportional to travel, non-linear or functional potentiometers have outputs that are not proportional to travel. Types of conformity are the same as the linear definitions noted above. Substitute the term "prescribed function line" in place of straight line reference to permit their application to non-linear potentiometers.

STANDARD DATA FORM: Point-x-point

HOW TO SPECIFY: Non-proportional functions are specified via graphs, specified outputs at travel references, or mathematically.

Conformity Tolerances:

Sine-Cosine and similar functions:

% peak to peak of applied voltage

Empirical Functions: $\pm x.xx\%$ of applied voltage

Mathematically: Absolute conformity

$e/E = f(\Theta) \pm C = A(\Theta) + B \pm C$

Where: A=defined slope

B=intercept at $\Theta=0$



An Electromotive Solutions Company

ISO 9001:2000 & AS9100:2004 Certified

2800 ANVIL STREET NORTH ST. PETERSBURG, FL 33710 USA

PHONE: (727) 347-2181 Fax: (727) 347-7520 Email: sales@vsensors.com

LINEARITY OR CONFORMITY, LIMITS, TOLERANCES

Up to this point all tolerances have been expressed as constant limits, i.e. $\pm x.xx\%$. However, limits may be specified in several ways.

Constant Limit: Permissible conformity deviations specified as a percentage of total applied voltage.

Zero to Peak Constant Limits: Permissible conformity deviations specified as a percentage of zero to peak applied voltage.

Note: The numerical value of zero to peak errors is equal to double that of equal value peak to peak errors. The zero to peak applied voltage is one half the total peak to peak voltage.

Proportional Limits: Permissible deviations in conformity specified as a percentage of the theoretical output ratio at the point of measurement. This is also known as "local linearity".

Note: Where the theoretical voltage ratio approaches zero, proportional limits may become impossible to obtain. Care must be taken to specify a practical tolerance in that region.

Modified Proportional Limits: Any combination of constant and proportional limits.

See Fig. 6 for examples of Limits.

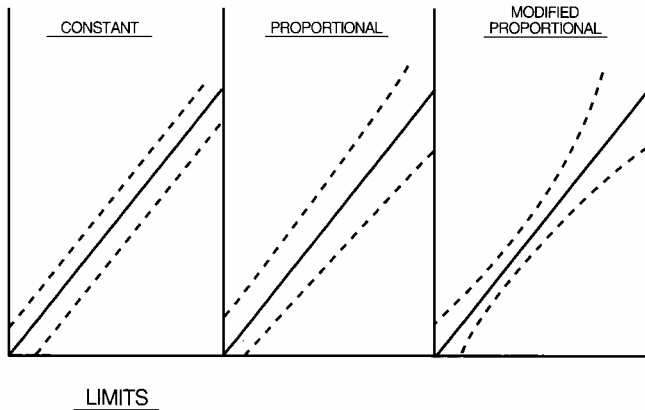

FIGURE 6

LINEARITY OR CONFORMITY CHANGE DUE TO RESISTIVE LOADING

The application of a resistive load to the wiper circuit of a potentiometer produces an error or change in the theoretical

output. **Sensor Systems LLC** potentiometers can be loaded in several ways. For example:

- between wiper and end
- between wiper and center tap ungrounded
- between wiper and center tap grounded
- between wiper and power supply CT grounded

The loading method and magnitude determine the magnitude of the resulting error and at what point in the function it is maximum. See Fig. 7A, 7B & 7C below for typical schematics.

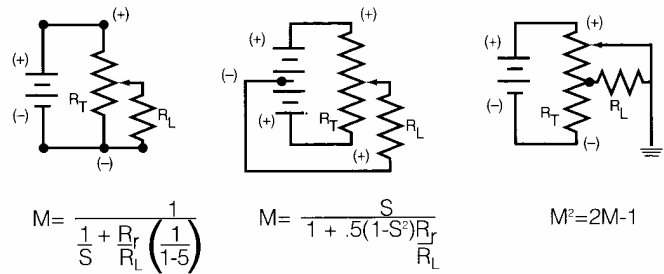

FIGURES 7A, 7B & 7C

Mathematically:

Where: S = Open circuit output
M = Loaded Output
 R_L = Load Resistance
 R_T = Total potentiometer Resistance

Maximum Error

The maximum error occurs at approximately 67% of the function angle in a potentiometer loaded per Fig. 7A and 67% of each half equidistant about the center tap in a potentiometer loaded per Fig. 7C.

Mathematically:

$\Delta = S - M = (P) (M) (S) (1 - S)$
Where: S = Open circuit output
M = Loaded output
 $P = \frac{R_T}{R_L}$

Therefore: Where: S = M
 $\Delta = S - M = P(M^2 - M^3)$
 $d\Delta/dm = P(2M - 3M^2) = 0^{dm}$
M = .667

 <p>SENSOR SYSTEMS, L. L. C. WWW.VSENSORS.COM</p>	<p>An Electromotive Solutions Company ISO 9001:2000 & AS9100:2004 Certified 2800 ANVIL STREET NORTH ST. PETERSBURG, FL 33710 USA PHONE: (727) 347-2181 Fax: (727) 347-7520 Email: sales@vsensors.com</p>
--	---

Sensor Systems LLC potentiometers are easily compensated for most loading configurations. As standard, 100:1 loads are preferred, loads as great as 10:1 are possible in certain configurations.

Note: Capacitive and inductive loading is not well tolerated, especially in discontinuous elements. Such loading is to be avoided in film potentiometric applications.

OUTPUT SMOOTHNESS (CP ONLY)

The purpose of the output smoothness specification is to detect, quantitatively, spurious variations in the output, which are not present in the input. Output smoothness is expressed as a percentage of the applied voltage measured over specified portions of the function travel, and includes the effects of contact resistance variations, and other forms of micro non-linearity.

The basis of output smoothness is to simulate actual usage by applying constant speed, and passing the output signal through a filter designed to simulate the response of the system for which the potentiometer is intended. The filtered output will show output anomalies, which occur over short periods with respect to the filter time constant. It will also show slower deviations which occur over periods in excess of the filter time constant, as variations in output level.

In practice, and unless otherwise specified, the output smoothness test in accordance with MIL-R-39023 is used as the standard. This specification provides for the following:

SPEED: 4RPM
 FILTER CIRCUIT: per Figure 8A (8Hz-160Hz)

Load: As required for conformity or linearity test. If none, then $R_L = 100 \times R_T$

Where: R_L = Load resistance,
 R_T = Potentiometer total resistance.

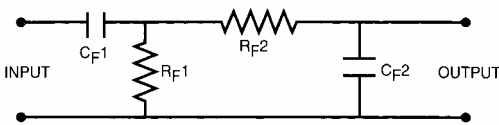

WHERE: $C_{F1} = 0.050 \text{ uf}$, $C_{F2} = 0.10 \text{ uf}$
 $R_{F1} = 400K$, $R_{F2} = 10K$

MIL-R-39023: OUTPUT SMOOTHNESS CIRCUIT

FIGURE 8A

TRAVEL INCREMENT: 1.0% of function angle.

SAMPLE ANALYSIS: See Fig. 8B

Note: Changes occurring at the normal points of abrupt changes in the output slope, start, end and reversal are not considered output smoothness effects and are not rejectable.

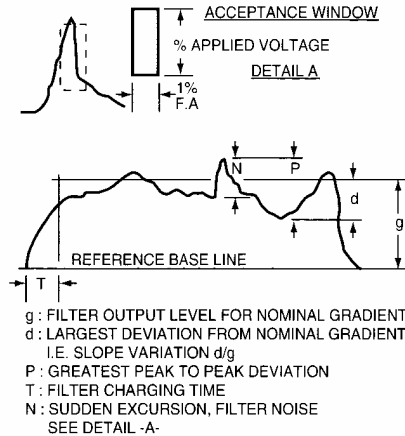

FIGURE 8B

CRITERIA:

Output smoothness characteristics to 0.01% of applied voltage over 1% of the function angle are available. The following MIL-R-39023 Specifications are commonly specified.

Symbol	Peak to Peak Voltage (e/E)	
	Initial (%)	Degraded (%)
A.....	2.0.....	2.2
B.....	0.5.....	0.7
C.....	0.1.....	0.15
D.....	0.025.....	0.04
E.....	0.010.....	0.02

NOISE (WW ONLY)

Mil-R-12934 Equivalent test for spurious variations in wire-wound output, due to parasitic transient resistance between the contact and resistive element, is determined by using Fig. 8C circuit.

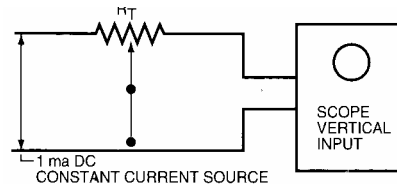

FIGURE 8C

The peak noise signal E_{PK} is noted while rotating the shaft at 4 RPM in both directions for 10 cycles.



WWW.VSENSORS.COM

An Electromotive Solutions Company
ISO 9001:2000 & AS9100:2004 Certified
 2800 ANVIL STREET NORTH ST. PETERSBURG, FL 33710 USA
 PHONE: (727) 347-2181 Fax: (727) 347-7520 Email: sales@vsensors.com

WIPER CURRENT

The normal working wiper current is 1 ma maximum, and such should be the specification of choice for the systems designer. Potentiometers with as much as 10 ma wiper current can be provided where necessary.

Wiper current develops under loaded conditions and affects output smoothness as well as conformity. For example:

Mathematically:

Load to Center Tap of Potentiometer:
(tap not grounded) see Fig. 9A

$$I_w = E / (1 + 2R_L / R_T) \left((0.5R_T) (R_L) + 0.5R_T \right) / .5R_T + R_L$$

Load to Center Tap of Power Supply:
See Fig. 9B

$$I_w = (R_L)(I_1 - I_2) - E = 0 = E / R_L$$

Current is maximum at each end, zero at electrical center of potentiometer.

Load to End
see Fig. 9C

$$I_w = E / (1 + R_L / R_T) \left((R_T \times R_L) / (R_T + R_L) \right) = E / R_L$$

Current is maximum at end farthest from load, decreasing to zero at load end.

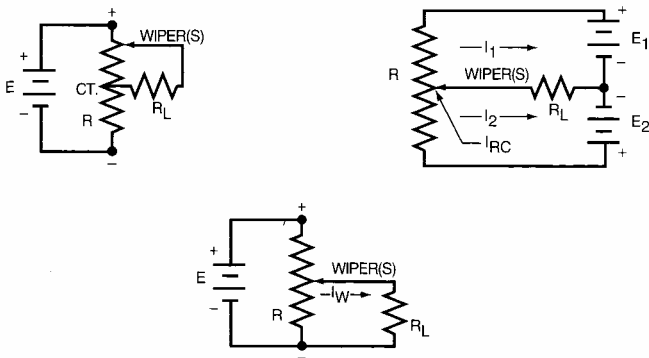

FIGURES 9A, 9B & 9C

QUADRATURE

Quadrature is defined as a phase shift between input and output caused by capacitive and inductive characteristics of potentiometers and loads, as well as circuit components.

The conductive plastic film used in **Sensor Systems LLC** potentiometers does not generate any significant quadrature under resistive loading conditions, and therefore, no special compensating circuitry is required.

POWER DISSIPATION

Power dissipation is the maximum power that can be dissipated safely by the potentiometer at a certain ambient temperature. It is expressed in wattage, and is equal to the square of excitation voltage, divided by the terminal resistance.

The power dissipation varies with size and is stated on the individual specification sheets contained herein.

DERATING: All **Sensor Systems LLC** potentiometers dissipate the maximum specified wattage @ 25°C and the linearly derated to zero wattage @ + 125°C. Deration to higher temperatures is possible in some configurations. See Fig. 10.

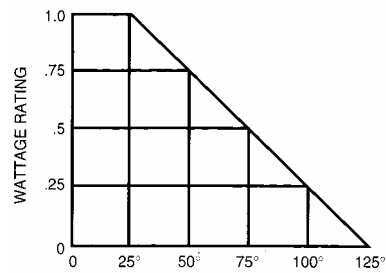

FIGURE 10

Mathematically where:

$$W_F = 1 - S(T_2 - T_1)$$

$$W_A = (W_F)(W_M)$$

W_F = Multiplier

W_M = Maximum wattage rating for device

W_A = Actual wattage rating @ temperature

S = Slope of derating curve-.01

T_2 = Temperature, operating

T_1 = Reference temperature @ 100% power = +25°C



An Electromotive Solutions Company

ISO 9001:2000 & AS9100:2004 Certified

2800 ANVIL STREET NORTH ST. PETERSBURG, FL 33710 USA

PHONE: (727) 347-2181 Fax: (727) 347-7520 Email: sales@vsensors.com

RELIABILITY CONSIDERATIONS

The reliability of a potentiometer depends on its ability to continue performing its intended function. Since the primary function is to provide a continuous and proportional voltage output, the primary reliability considerations are continuity and proportional voltage output. A failure in continuity is always catastrophic as the device is no longer acting as a potentiometer.

The primary constituents of continuity are:

- Wiper contact to conductive surface.
- Continuous conductive surface.
- Wiper (output) and excitation terminal continuity.

Wipers

Sensor Systems LLC uses two types of wiper construction, flat stamping, and circular wire form. Both types exhibit totally separate and independent arms. Each arm is designed to have different resonant frequencies, thereby precluding discontinuity under vibration. The wiper materials are matched to the surfaces being wiped to minimize wear. True redundancy is obtained by first welding all wipers to their respective mounts, followed by soldering over the welded section.

Probability of Failure of Wiper Contacts

- The probability that an event will happen is the ratio of the number of favorable cases to the entire number of possible cases, provided all cases are equally likely to occur.
- The probability of simultaneous occurrence of two independent events whose respective probabilities are a and b, is a x b.
- The probability of occurrence of one or the other of two mutually exclusive events whose respective probabilities are a and b is a + b.

Case1: Will maintain contact

Case 2: Will not maintain contact=Failure case.

Probability of Failure: 1/2

Probability of Simultaneous Failure =

$$(1/2)^1, (1/2)^2, (1/2)^3, (1/2)^N, = (1/2)^N$$

Failure Probability Ratio:

(Multiple vs. single wiper arm) =

$$\frac{(1/2)^N}{1/2} = (1/2)^{N-1}$$

Therefore: Multiple arms (N) are $(1/2)^{N-1}$ times as reliable as a single wiper. The standard four (4) arm wiper utilized in **Sensor Systems LLC** potentiometers is, therefore, eight (8) times less likely to lose continuity as a single wiper.

In summary, the **Sensor Systems LLC** Potentiometer offers an extreme high degree of reliability, and true redundancy throughout.

ENVIRONMENT

Sensor Systems LLC potentiometers meet all the environmental requirements of MIL-R-39023 and MIL-R-12934.

Temperature Coefficient of Resistance (TCR)-(CP Only)

Per MIL-R39023 and to -400PPM/°C

Vibration, Shock, Acceleration

Sensor Systems LLC potentiometers easily withstand high G forces without losing continuity. A momentary discontinuity equal to or greater than 0.1ms is generally considered a failure. Wipers are so arranged that each separate wiper arm is independent and has a different natural frequency. This coupled with the low wiper mass, results in an extremely stable assembly. No increase in torque is necessary under the "preferred" values listed below:

Environment	Preferred	Special Design Capability To
Sinusoidal Vibration	50 G's or less	100 G's, 5-2KHZ
Random Vibration	0.04PSD, 7.3G RMS	0.4PSD, 23.1G RMS
Sinusoidal Shock (11ms)	50 G's or less	150 G's
Sawtooth Shock (7ms)	30 G's or less	100 G's
Acceleration	50 G's or less	150 G's

Note: Some special designs have been tested to 300G Acceleration, 150G Sinusoidal Vibration, 0.6PSD Random Vibration, and 200G Sinusoidal Shock without damage, degradation or loss of continuity. Consult factory with such requirements.

Effect of Life on Resistance, Output Smoothness, Conformity and Torque (Conductive Plastic Only)

Under the test conditions per Mil-R-39023, resistance and conformity levels remain well within specification. See Fig. 11 for graphical presentation of data. Typical resistance values were approx. .05% $\Delta R/10^6$ cycles with worst case .075% $\Delta R/10^6$ cycles. Typical output smoothness values were +.008 in/oz/ 10^6 cycles in the first 5 x 10^6 cycles and +.002 in/oz/ 10^6 cycles thereafter. Conformity values were $\Delta .00690/10^6$ cycles.

 <p>SENSOR SYSTEMS, L. L. C. WWW.VSENSORS.COM</p>	<p><i>An Electromotive Solutions Company</i> ISO 9001:2000 & AS9100:2004 Certified 2800 ANVIL STREET NORTH ST. PETERSBURG, FL 33710 USA PHONE: (727) 347-2181 Fax: (727) 347-7520 Email: sales@vsensors.com</p>
---	---

**Effect of Load Life on Resistance
(Conductive Plastic Only)**

900 hrs. of load life per MIL-R-39023 generally results in resistance changes of less than 1%, and worst case less than 1.5%. There is virtually no change in other electrical characteristics.

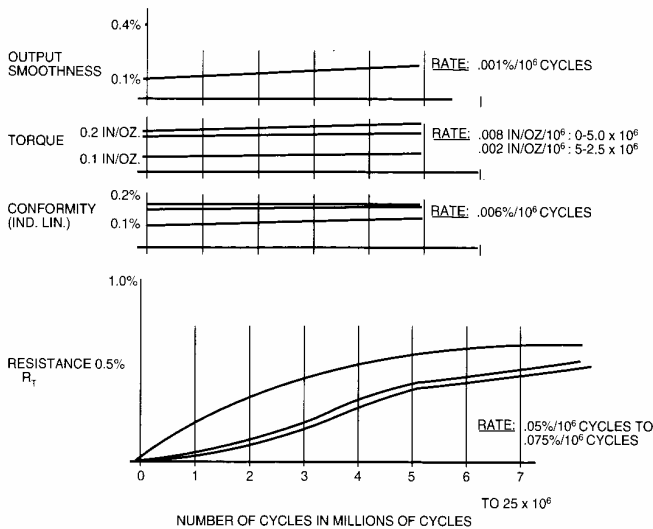

FIGURE 11

MECHANICAL CHARACTERISTICS

Rotary Potentiometers

TORQUE:

Sensor Systems LLC potentiometers are designed for low torque actuation, Unless otherwise specified, ball bearings are used for all rotary potentiometers. Since the wiper/film coefficient of friction is low, the net unit torque is well below most system requirements.

Special "low torque" designs are available where necessary. The starting torque levels are enumerated on the individual data sheets.

MOMENT OF INERTIA:

Since the internal rotating masses are small, moment of inertia is generally well below most system requirements. The moment of inertia for each model is listed on the individual data sheets.

Rectilinear Potentiometers

ACTUATING FORCE:

All Sensor Systems LLC rectilinear potentiometers incorporate extruded or machined ways, which are matched to sliding blocks carrying film and commutator wipers. The

configurations of the ways and block are so designed to minimize misfit under temperature environments. Hence, actuating force under temperature extremes closely matches initial values.

ANTI-ACCELERATION & ANTI-TEMPERATURE DESIGN:

All standard Sensor Systems LLC rectilinear potentiometers incorporate a spring load between the shaft and wiper block designed to exceed forces introduced from high shaft accelerations. Under such forces, the spring load will keep the block in intimate contact with the shaft so as to maintain the block/shaft positional integrity throughout the force cycle.

The spring force also compensates for thermal mismatch between the shaft and the block materials, by allowing the block to grow or shrink with respect to the shaft without permanent setting of the block material.

As a result, the block never becomes loose, or changes its relationship with respect to the shaft.

MISALIGNMENT FEATURE

Shaft misalignment is available as a standard configuration on "Tuff-Line" Model 111, and is available on other rectilinear models by special order.

Consult Sensor Systems LLC Applications Engineering Staff with your specific requirements.

RUGGEDNESS

The square configured models incorporate single piece "U" or box extrusions which are highly resistant to mechanical distortion. The round configured models incorporate single piece "U" or clamshell extrusions, with single piece tube type covers. A body within a body construction results which is extremely resistant to distortion, providing a most rugged construction.

Stainless steel shafts are used throughout to complement the above.

ROTATING SHAFT FEATURE

Most rectilinear models incorporate or can incorporate rotatable shafts with threaded ends which can be threaded to stationary mounts.

Consult the individual model sheets or Sensor Systems LLC Applications Engineering Staff.

 <p>SENSOR SYSTEMS, L. L. C. WWW.VSENSORS.COM</p>	<p><i>An Electromotive Solutions Company</i> ISO 9001:2000 & AS9100:2004 Certified 2800 ANVIL STREET NORTH ST. PETERSBURG, FL 33710 USA PHONE: (727) 347-2181 Fax: (727) 347-7520 Email: sales@vsensors.com</p>
---	---